

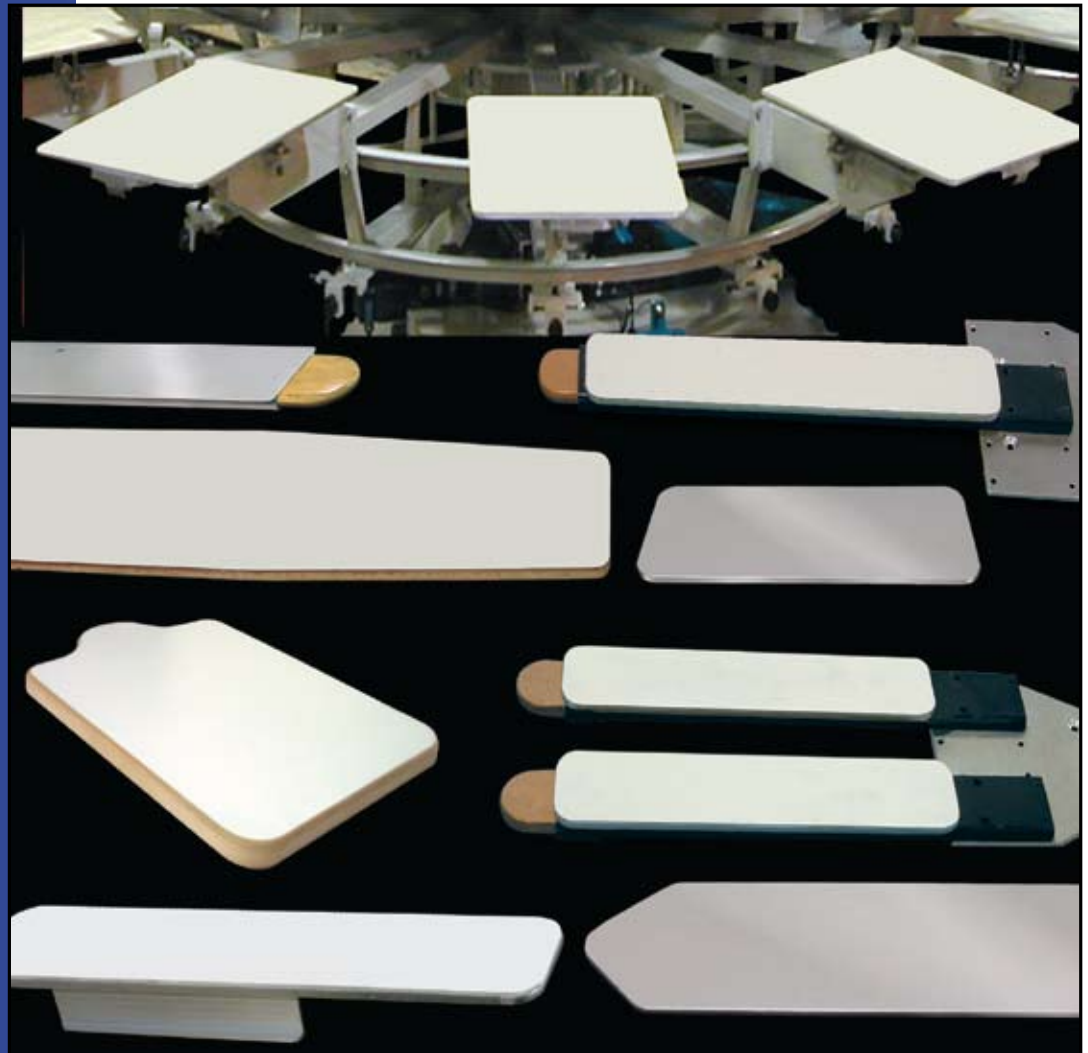

STAY-FLAT™ ALUMINUM AND WOODEN PALLETS FOR ALL TEXTILE EQUIPMENT

INCLUDING PALLET RUBBER, PALLET BRACKETS, TAPE AND PALLET ADHESIVES



**OEM Replacement Parts &
Remanufacturing Services
for the Screen Printer**



*A Division of
The A.W.T. World Trade Group
Chicago, IL 60641 USA*

www.gpiparts.com

PALLETS

GRAPHIC PARTS INTERNATIONAL INC.

YOUR COMPLETE MANUFACTURING SOURCE FOR HIGH-QUALITY PALLETS FOR ALL TYPES OF APPLICATIONS AND EQUIPMENT

G.P.I.'s Stay-Flat™ high performance pallets are manufactured in aluminum or wood. They are designed to remain as smooth and flat as possible when exposed to high heat and moisture in high-volume production shops. Hundreds of standard and specialty sizes are manufactured by G.P.I. in a choice of configurations to meet the needs of any textile screen printer.

- Wood, solid aluminum or aluminum honeycomb
- With or without heat-resistant rubber covering
- Hundreds of shapes and sizes for all applications
- Most bracket configurations available

Stay-Flat™ Textile Pallets are G.P.I.'s exclusive design. We have traveled worldwide to research the many types of textile pallets manufactured. Our technicians developed these top-of-the-line pallets based on international knowledge of printing equipment and pallet applications.

Aluminum is the preferred choice for all G.P.I. pallets because it stays flat and has extremely long life. Aluminum pallets also meet textile screen printing requirements for all applications. Stay-Flat wood pallets are also available. These pallets use a special wood formulation to provide long-lasting, reliable performance.

All Stay-Flat aluminum pallets have the highest quality printing surface. They are covered with a unique rubber that is long lasting and highly heat resistant. G.P.I.'s specially formulated rubber holds up longer to the extreme temperatures of spot or flash cure units. Applied to the pallet with high-temperature resistant adhesive, it can be stripped and replaced as needed. G.P.I. has tested and concluded that the thickness of rubber we use is best for textile screen printing quality on either manual or automatic equipment.

G.P.I. has been manufacturing textile pallets, pallet parts and accessories to the highest standards for over 20 years. Our years of research and experience have produced an excellent pallet product. Stay-Flat pallets can make your textile production cost effective and smooth.

Replacement Stay-Flat pallets can be custom made to any size. Simply submit a drawing showing the size and mounting holes and/or bracket locations.

Stay Flat Aluminum Pallets are manufactured in standard designs to fit:

M&R*

Formula
Challenger
Gauntlet
Blue Max
and more

Advance-American

Centurian
Multiprinter
Rototex

A.W.T.

Print-Tex
Econo-Tex

Atlas

Precision*

Ultimate
Versa-Oval
Premier
OPP Clip On
OPM Clip On

MHM*

SP Series

TAS*

200 Series
300 Series
400 Series

Chapparel*

OPP Slip On
EMO Style

Tuf*

Olympian
Javelin

Harco*

Anatol*

Lawson*

Vastex*

Hopkins*

Hix*

and hundreds of others around the world.

***G.P.I. is not affiliated with these companies**

TABLE OF CONTENTS

Pallet Shapes	3
Pallets for Domestic & Foreign Equipment	4
Wooden Replacement Pallets	5
Pallet Adhesives & Coverings	6
Specialty Applications.....	7-8
Conversion Kits	9



A Division of The A.W.T. World Trade Group

4321 N. Knox Ave. • Chicago, IL 60641-1906 USA

800.444.PART (within the USA) • 773.725.4900 • Fax: 773.777.0909

parts@gpiparts.com • www.gpiparts.com

Pallet shapes & sizes available for every application

All of these pallets are available with a large selection of mounting hardware, pallet brackets and specially formulated heat-resistant pallet rubber in wood, solid aluminum or aluminum honeycomb. Pallets are also available without rubber covering.

Custom Made Pallets

Based on specific customer requirements, G.P.I. manufactures customized pallet sizes and shapes. Pallet material, covering, shape and mounting hardware are built to order. Custom orders may include a specialty item such as two-sided pallets for leg or sleeve printing.

Some Standard Shirt Pallet Shapes

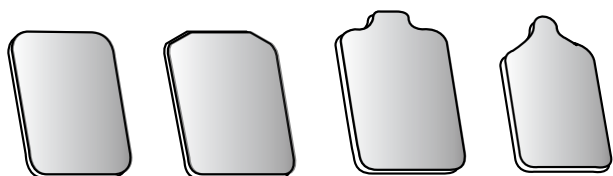

In addition to the applications shown below, we have:

- T-Shirt pallets
- Pocket & pant leg pallets
- Sock or hosiery pallets
- All-over pallets for seam-to-seam printing
- Expandable size pallets
- Jacket holddown stretch frames

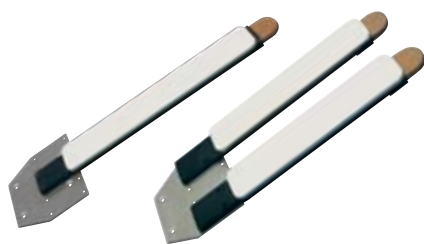

Single and Double Sleeve for
Advance-American



Single Sleeve for
M&R



Double Sleeve for
M&R



Umbrella
Holddown



Pocket Pallet for
M&R



Double Sleeve for
Precision



Sock Pallet for
MHM



Glove Pallet



Pallet Tongue for
American Rototex

Graphic Parts International manufactures pallets for foreign and domestic brands of screen printing equipment.

If you don't see what you need, just call us and we will custom make pallets to fit your application.



A Division of The A.W.T. World Trade Group

4321 N. Knox Ave. • Chicago, IL 60641-1906 USA

800.444.PART (within the USA) • 773.725.4900 • Fax: 773.777.0909

parts@gpiparts.com • www.gpiparts.com

STAY-FLAT™ ALUMINUM PALLETS FOR ALL DOMESTIC AND FOREIGN SCREEN PRINTERS

This is only a sample list of pallets; Thousands more are available

Pallets for AWT Equipment (Aluminum with Pallet Rubber)

Print-Tex™

Cat. No.	Size
RP-1016-GAO	10" x 16" (25.4 x 40.6 cm)
RP-1116-GAO	11" x 16" (27.9 x 40.6 cm)
RP-1216-GAO	12" x 16" (30.5 x 40.6 cm)
RP-1516-GAO	15" x 16" (38.1 x 40.6 cm)
RP-1520-GAO	15" x 20" (38.1 x 50.8 cm)
RP-1618-GAO	16" x 18" (40.6 x 45.7 cm)
RP-1624-GAO	16" x 24" (40.6 x 61.0 cm)
RP-1824-GAO	18" x 24" (45.7 x 61.0 cm)
RP-1832-GAO	18" x 32" (45.7 x 81.3 cm)
RP-1920-GAO	19" x 20" (48.3 x 50.8 cm)
RP-1928-GAO	19" x 28" (48.3 x 71.1 cm)
RP-2016-GAO	20" x 16" (50.8 x 40.6 cm)

Econo-Tex™

Cat. No.	Size
RP-1016E-GAO	10" x 16" (25.4 x 40.6 cm)
RP-1216E-GAO	12" x 16" (30.5 x 40.6 cm)
RP-1516E-GAO	15" x 16" (38.1 x 40.6 cm)
RP-1518E-GAO	15" x 18" (38.1 x 45.7 cm)
RP-1822E-GAO	18" x 22" (45.7 x 60.0 cm)
RP-419SE-GAO	4" x 19" (10.2 x 48.3 cm)

Pallets for M&R Equipment (Aluminum with Pallet Rubber)

For Use with Blue Max, Formula, Gauntlet, Challenger, and Jumbo

Cat. No.	Size
RP-0616-GM2	6" x 16" (15.2 x 40.6 cm)
RP-0622-GM2	6" x 22" (15.2 x 55.9 cm)
RP-0816-GM2	8" x 16" (20.3 x 40.6 cm)
RP-0822-GM2	8" x 22" (20.3 x 55.9 cm)
RP-1016-GM2	10" x 16" (25.4 x 40.6 cm)
RP-1117-GM2	11" x 17" (28.0 x 43.2 cm)
RP-1122-GM2	11" x 22" (28.0 x 55.9 cm)
RP-1022-GM2	10" x 22" (25.4 x 55.9 cm)
RP-1216-GM2	12" x 16" (30.5 x 40.6 cm)
RP-1222-GM2	12" x 22" (30.5 x 55.9 cm)
RP-1422-GM2	14" x 22" (35.6 x 55.9 cm)
RP-1516-GM2	15" x 16" (38.1 x 40.6 cm)
RP-1621-GM2	16" x 21" (40.6 x 53.3 cm)
RP-1622-GM2	16" x 22" (40.6 x 55.9 cm)
RP-1820-GM2	18" x 20" (45.7 x 50.8 cm)
RP-1822-GM2	18" x 22" (45.7 x 55.9 cm)
RP-1926-GM2	19" x 26" (48.3 x 66.0 cm)
RP-2224-GM2	22" x 24" (55.9 x 61.0 cm)
RP-2525-GM2	25" x 25" (63.5 x 63.5 cm)
RP-2536-GM2	25" x 36" (63.5 x 91.4 cm)

RP-2542-GM2	25" x 42" (63.5 x 106.7 cm)
RP-2630-GM2	26" x 30" (66.0 x 76.2 cm)

Pallets for American Equipment (Aluminum with Pallet Rubber)

Centurian™/ Multiprinter

Cat. No.	Size
RP-1014-GA1	10" x 14" (25.4 x 35.6 cm)
RP-1016-GA1	10" x 16" (25.4 x 40.6 cm)
RP-1214-GA1	12" x 14" (30.5 x 35.6 cm)
RP-1516-GA1	15" x 16" (38.1 x 40.6 cm)
RP-2028-GA1	20" x 28" (50.8 x 71.1 cm)
RP-1616-GA1	16" x 16" (40.6 x 40.6 cm)
RP-1620-GA1	16" x 20" (40.6 x 50.8 cm)
RP-1621-GA1	16" x 21" (40.6 x 53.3 cm)

Pallets for MHM Equipment

All-aluminum pallets for MHM equipment are made from either laminated honeycomb or solid aluminum to avoid warping. Larger pallets have support bars to prevent against bending under increased squeegee pressure.

MHM SP-2000

Cat. No.	Size
RP-1339-GM3	12.60" x 39.37" (32 x 100 cm)
RP-1639-GM3	15.75" x 39.37" (40 x 100 cm)
RP-1839-GM3	17.75" x 39.37" (45 x 100 cm)
RP-3047-GM3	29.50" x 47.25" (75 x 102 cm)

Pallets for Anatol Equipment

Cat. No.	Size
RP-1022-GA8	10" x 22" (25.4 x 55.9 cm)
RP-1222-GA8	12" x 22" (30.5 x 55.9 cm)
RP-1622-GA8	16" x 22" (40.6 x 55.9 cm)
RP-1822-GA8	18" x 22" (45.4 x 55.9 cm)

Pallets for Progressive Equipment

Cat. No.	Size
RP-0622-GP4	6" x 22" (15.2 x 55.9 cm)
RP-0822-GP4	8" x 22" (20.3 x 55.9 cm)
RP-1022-GP4	10" x 22" (25.4 x 55.9 cm)
RP-1516-GP4	15" x 16" (38.1 x 40.6 cm)
RP-1822-GP4	18" x 22" (45.7 x 55.9 cm)
RP-2630-GP4	26" x 30" (66.0 x 76.2 cm)

Pallets for TUF Equipment

Cat. No.	Size
RP-1023-GT2	10" x 23" (25.4 x 58.4 cm)
RP-1323-GT2	13" x 23" (33.0 x 58.4 cm)
RP-1723-GT2	17" x 23" (43.2 x 58.4 cm)
RP-2236-GT2	22" x 36" (55.9 x 91.4 cm)
RP-418S-GT2	4" x 18" (10.2 x 45.7 cm)



A Division of The A.W.T. World Trade Group

4321 N. Knox Ave. • Chicago, IL 60641-1906 USA
800.444.PART (within the USA) • 773.725.4900 • Fax: 773.777.0909
parts@gpiparts.com • www.gpiparts.com

STAY-FLAT™

WOODEN REPLACEMENT PALLETS

Replacement pallets for:

- Atlas
- Chapparral
- Harco
- Hix
- Hopkins
- Jennings
- Lawson
- Ranar
- TAS
- Vastex

and other manufacturers equipment

G.P.I. has tested hundreds of compounds and treated woods for warping due to excessive flash curing heat and moisture. We have achieved the closest formulation to aluminum available.

Our pallets are manufactured with perfectly round corners, rounded edges and a white laminated surface.

We can also cover the wooden pallet with formulated heat-resistant rubber using a high-temperature adhesive to extend pallet life.

Our rubber covering also provides a perfect printing surface very similar to the surface of high-grade aluminum pallets. Our Stay-Flat™ wooden pallets will easily mount to your existing brackets (modification or inserts may be required).

Instructions for using your original bracket as a template for drilling the holes are included.

Bracket hardware is not included with the replacement pallets. Brackets for most manual textile printers must be ordered separately.

Stay-Flat wooden pallets come in many standard sizes. We can also custom manufacture your pallets to order...any size. Simply submit a worksheet/drawing showing the size and shape required.

Rectangular Shaped Pallets with Radius Corners

Cat. No.	Size
RPW-1012-GPI	10" x 12" x 3/4" (25.4 x 30.5 x 1.9 cm)
RPW-1014-GPI	10" x 14" x 3/4" (25.4 x 35.6 x 1.9 cm)
RPW-1016-GPI	10" x 16" x 3/4" (25.4 x 40.6 x 1.9 cm)
RPW-1214-GPI	12" x 14" x 3/4" (30.5 x 35.6 x 1.9 cm)
RPW-1216-GPI	12" x 16" x 3/4" (30.5 x 40.6 x 1.9 cm)
RPW-1414-GPI	14" x 14" x 3/4" (35.6 x 35.6 x 1.9 cm)
RPW-1618-GPI	16" x 18" x 3/4" (40.6 x 45.7 x 1.9 cm)
RPW-1620-GPI	16" x 20" x 3/4" (40.6 x 50.8 x 1.9 cm)
RPW-1818-GPI	18" x 18" x 3/4" (45.7 x 45.7 x 1.9 cm)
RPW-1820-GPI	18" x 20" x 3/4" (45.7 x 50.8 x 1.9 cm)

Rectangular Shaped Pallets with Radius Corners and Neck

Cat. No.	Size
RPWN-1012-GPI	10" x 12" (25.4 x 30.5 cm)
RPWN-1014-GPI	10" x 14" (25.4 x 35.6 cm)
RPWN-1016-GPI	10" x 16" (25.4 x 40.6 cm)
RPWN-1021-GPI	10" x 21" (25.4 x 53.3 cm)
RPWN-1214-GPI	12" x 14" (30.5 x 35.6 cm)
RPWN-1216-GPI	12" x 16" (30.5 x 40.6 cm)
RPWN-1414-GPI	14" x 14" (35.6 x 35.6 cm)
RPWN-1618-GPI	16" x 18" (40.6 x 45.7 cm)
RPWN-1620-GPI	16" x 20" (40.6 x 50.8 cm)
RPWN-1818-GPI	18" x 18" (45.7 x 45.7 cm)
RPWN-1820-GPI	18" x 20" (45.7 x 50.8 cm)

Single-Sleeve Pallets with Rounded Corners

Cat. No.	Size
RPWS-0210-GPI	2" x 10" x 3/4" (5.1 x 25.4 x 1.9 cm)
RPWS-0414-GPI	4" x 14" x 3/4" (10.2 x 35.6 x 1.9 cm)
RPWS-0518-GPI	5" x 18" x 3/4" (12.7 x 45.7 x 1.9 cm)

Double-Sleeve Pallets with Rounded Corners

Cat. No.	Size
RPWSD-0212-GPI	2" x 12" x 3/4" (5.1 x 30.5 x 1.9 cm)
RPWSD-0416-GPI	4" x 16" x 3/4" (10.2 x 40.6 x 1.9 cm)
RPWSD-0520-GPI	5" x 20" x 3/4" (12.7 x 50.8 x 1.9 cm)

Single Pant Leg Pallets with Rounded Corners

Cat. No.	Size
RPWP-0312-GPI	3" x 12" x 3/4" (7.6 x 30.5 x 1.9 cm)
RPWP-0424-GPI	4" x 24" x 3/4" (10.2 x 61 x 1.9 cm)
RPWP-0632-GPI	6" x 32" x 3/4" (15.2 x 81.3 x 1.9 cm)

Double Pant Leg Pallets with Rounded Corners

Cat. No.	Size
RPWPD-0312-GPI	3" x 12" x 3/4" (7.6 x 30.5 x 1.9 cm)
RPWPD-0424-GPI	4" x 24" x 3/4" (10.2 x 61 x 1.9 cm)
RPWPD-0632-GPI	6" x 32" x 3/4" (15.2 x 81.3 x 1.9 (cm)

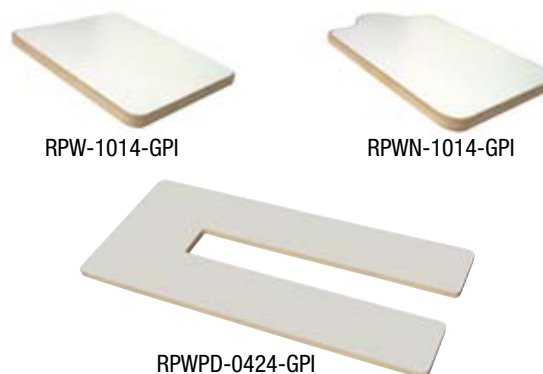

A Division of The A.W.T. World Trade Group

4321 N. Knox Ave. • Chicago, IL 60641-1906 USA

800.444.PART (within the USA) • 773.725.4900 • Fax: 773.777.0909

parts@gpiparts.com • www.gpiparts.com

SPECIALTY APPLICATIONS

Sleeve and Pant Leg Pallets for Advance/American Equipment

These pallets fit all American Rototex and Multiprinters. The four inch and five inch pallets are for standard sleeves, and the seven inch pallets are for extra large sleeves and pant legs. One mounting plate with 12 holes is included with your first purchase of any G.P.I sleeve or pant leg pallet. Additional pallets may be purchased without the mounting plate for cost savings and easy pallet changeovers.

Sleeve and Pant Leg Pallets for American Centurian, Rototex and Multiprinters

Cat. No.	Size	Description
RP-419S-GA1	4" x 19" (10.2 x 48.3 cm)	Aluminum Single Sleeve Pallet
RP-419D-GA1	4" x 19" (10.2 x 48.3 cm)	Aluminum Double Sleeve Pallet
RP-424S-GA1	4" x 24" (10.2 x 61 cm)	Aluminum Single Sleeve Pallet
RP-424D-GA1	4" x 24" (10.2 x 61 cm)	Aluminum Double Sleeve Pallet
RP-519S-GA1	5" x 19" (12.7 x 48.3 cm)	Aluminum Single Sleeve Pallet
RP-519D-GA1	5" x 19" (12.7 x 48.3 cm)	Aluminum Double Sleeve Pallet
RP-730SL-GA1	7" x 30" (17.8 x 76.2 cm)	Aluminum Single Leg Pallet



Sleeve and Pant Leg Pallets for American Champrint

Cat. No.	Size	Description
RP-428S-CHP	4" x 28" (10.2 x 71.1 cm)	Aluminum Single Sleeve Pallet
RP-728SL-CHP	7" x 28" (17.8 x 71.1 cm)	Aluminum Single Leg Pallet



Sleeve and Pant Leg Pallets for A.W.T. Textile Equipment

Cat. No.	Size	Description
RP-619S-GAO	6" x 19" (15.2 x 48.3 cm)	Aluminum Single Sleeve Pallet
RP-730D-GAO	7" x 30" (17.8 x 76.2 cm)	Aluminum Double Leg Pallet
RP-419S-GAO	4" x 19" (10.2 x 48.3 cm)	Aluminum Single Sleeve Pallet
RP-419D-GAO	4" x 19" (10.2 x 48.3 cm)	Aluminum Double Sleeve Pallet
RP-430D-GAO	4" x 30" (10.2 x 76.2 cm)	Aluminum Double Sleeve Pallet
RP-730SL-GAO	7" x 30" (17.8 x 76.2 cm)	Aluminum Single Leg Pallet

Jacket Holddown Stretch Frames*

Now you can hold down most two layer materials, such as jackets, securely on the pallet for printing. G.P.I. manufactures standard and special size stretch frames for all manufacturers. Jacket holddown frames can be custom made to any size. Stretch frame is complete with frame, bracket, and aluminum or wood Stay Flat™ rubber coated pallets.

Cat. No.	Size	Description
JHD-1516	15" x 16" (38.1 x 40.6 cm)	Jacket Holddown
JHD-1516-GAO	15" x 16" (38.1 x 40.6 cm)	Jacket Holddown with Support
JHD-1822	18" x 22" (45.7 x 55.9 cm)	Jacket Holddown

*Includes: Frame, bracket, & aluminum or wood Stay-Flat™ pallet with heat-resistant rubber.



Universal Pocket Pallet Attachment

Cat. No.	Size	Description
GPIPA-1	4" wide	Universal pocket attachment



Glove Pallet

* Please contact G.P.I. for more information.



Umbrella Holddown Attachment with Pallet*

* Please contact G.P.I. for more information.



A Division of The A.W.T. World Trade Group

4321 N. Knox Ave. • Chicago, IL 60641-1906 USA

800.444.PART (within the USA) • 773.725.4900 • Fax: 773.777.0909

parts@gpiparts.com • www.gpiparts.com

SPECIALTY APPLICATIONS

Sleeve and Pant Leg Pallets for Advance-American Equipment

These pallets fit all models of American Rototex, Automatic Rototex and Multiprinters. The 4" pallets are for standard sleeves. The 7" pallets are for pant legs or extra-large sleeves. Included with the first purchase of a sleeve or pant pallet from G.P.I. is a mounting plate with 12 holes to fit single sleeve/pant pallets or double sleeve/pant pallets. Additional pallets are purchased without the mounting plate for savings and easy pallet changeover.

Sleeve and Pant Leg Pallets for M&R Equipment

These aluminum textile pallets work great on sleeves, pant legs and shirt pockets. If you don't see the size or shape you need, contact us and we will manufacture a custom sized or shaped pallet which will fit your application.

Cat. No.	Size	Description
RP-418S-GM2	4" x 18" (10.2 x 45.7 cm)	Aluminum Single Sleeve Pallet
RP-423S-GM2	4" x 23" (10.2 x 58.4 cm)	Aluminum Single Sleeve Pallet
RP-0522-GM2	5" x 22" (12.7 x 55.9 cm)	Aluminum Single Sleeve Pallet
RP-527S-GM2	5" x 27" (12.7 x 68.6 cm)	Aluminum Single Pocket Pallet
RP-622S-GM2	6" x 22" (15.2 x 55.9 cm)	Aluminum Single Sleeve Pallet
RP-722S-GM2	7" x 22" (17.8 x 55.9 cm)	Aluminum Single Sleeve Pallet
RP-723S-GM2	7" x 23" (17.8 x 58.4 cm)	Aluminum Single Sleeve Pallet
RP-822SL-GM2	8" x 22" (20.3 x 55.9 cm)	Aluminum Single Leg Pallet
RP-836SL-GM2	8" x 36" (20.3 x 91.4 cm)	Aluminum Single Leg Pallet
RP-418D-GM2	4" x 18" (10.2 x 45.7 cm)	Aluminum Double Sleeve Pallet
RP-423D-GM2	4" x 23" (10.2 x 58.4 cm)	Aluminum Double Sleeve Pallet



Single Sleeve



Double Sleeve



Pocket Pallet



Single Leg



A Division of The A.W.T. World Trade Group

4321 N. Knox Ave. • Chicago, IL 60641-1906 USA

800.444.PART (within the USA) • 773.725.4900 • Fax: 773.777.0909

parts@gpiparts.com • www.gpiparts.com



CONVERSION KITS

Upgrade Your Wood Pallets to Stay-Flat™ Aluminum Pallets Easily
With Conversion Kits from G.P.I. , for use with:

Jennings, Lawson, Vastex, Hopkins, Atlas , Harco, Chaparral and Others

G.P.I. conversion kits make it easy for you to replace your original wood pallets with new aluminum pallets. Mounting bracket diagrams shown at right.

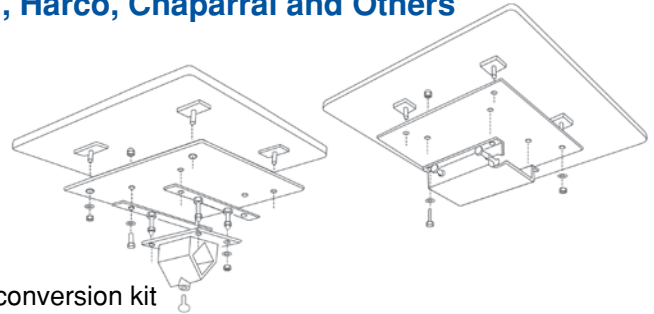

Cat. No.	Description
RP-WOOD-S	Wood to aluminum textile pallet conversion kit

Heat-resistant White Pallet Rubber and Adhesive for Textile Pallets

Cat. No.	Description
SFWPR-36	Smooth finish white nitrile rubber, 12" x 12" (30.5 x 30.5 cm), 1/8" (3.175 mm) thick, 60 durometer.
SFWPR-36F	Smooth finish white nitrile rubber, 36" (91.44 cm) wide, 1/8" (3.175 mm) thick, 60 durometer.
SFWPR-48	Smooth finish white nitrile rubber. 48" (122 cm) wide, 1/8" (3.175 mm) thick, 60 durometer.
SFWPR-48F	Smooth finish white nitrile rubber. 48" (122 cm) wide, 1/8" (3.175 mm) thick, 60 durometer.
GA1-PNT003	High Performance Contact Adhesive (Per Qt.)
GA1-PNT003HT	High Temperature Pallet Adhesive - 32 Oz. Can



Pallet Brackets Available for M&R, Progressive, Hopkins, Harco and Atlas

Cat. No.	Description
RPGM2BRKT	M&R pallet bracket
RPGP4BRKT	Progressive pallet bracket
RPGH2BRKT	Hopkins T-shirt pallet original extruded bracket complete with hardware
RPGH2BRKT	Hopkins T-shirt pallet black metal bracket complete with hardware
RPGH1BRKT	Harco pallet bracket
RPGA4BRKT	Atlas pallet bracket

Pallet Bracket Adhesive Tape

Super strong, 4" double-sided adhesive pallet tape can be used wherever pallet mounting bracket has no means to secure the pallet to the hardware. Available only in one-size roll.

Cat. No.	Description
GPITT4604	Double-sided adhesive pallet tape, 4"wide x 60 yards

MAKE YOUR OWN PALLETS

G.P.I. extrudes and manufactures most pallet components. Using our materials and technical expertise you can:

- Make your own pallets
- Resurface your pallets
- Repair your pallets



A Division of The A.W.T. World Trade Group
4321 N. Knox Ave. • Chicago, IL 60641-1906 USA
800.444.PART (within the USA) • 773.725.4900 • Fax: 773.777.0909
parts@gpiparts.com • www.gpiparts.com

PALLET ADHESIVES & COVERINGS

Pallet Mask™ 1 High Tack Two Sided Pallet Adhesive Cloth

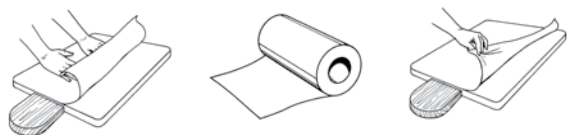

Secure T-shirts and other textiles on your pallet with Pallet Mask™1 High-Tack Adhesive. With equal amounts of adhesive on both cloth sides, Pallet Mask holds textiles in place while it guards against wrinkles and misprints. Simply place on pallet, cut to size, and remove protective sheet to adhere. Pallet Mask's adhesive remains strong under flash curing, helping maintain registration throughout your entire run. If any lint accumulates on the surface, simply wipe off with water and you can continue production without any delay. When covered with Pallet Mask, your pallets will no longer need protective paper.



Cat. No.	Roll Size	Description
TT-142S	14" x 5 yds	Pallet Mask Trial Size
TT-142	14" x 36 yds (36cm x 33m)	Pallet Mask Std. Roll- 4 rolls per case
TT-143	18" x 36 yds (46cm x 33m)	Pallet Mask Wide Roll- 4 rolls per case

Table-Tac™ Water Soluble Table Adhesive for Textile Holddown

- Easily secures substrate to pallet
- Easy to use – apply, air dry and print
- Worker friendly- no atomization
- No waste alternative to spray adhesives
- No adhesive residue- won't clog or cover equipment
- Easy-to-retack



Table-Tac™ Water Soluble Table Adhesive securely holds textiles, thin substrates, and even some plastic in place on your pallets. With Table-Tac, the need for an expensive vacuum table to maintain registration is eliminated. Unlike spray adhesives, Table-Tac is brushed or carded on, eliminating waste and keeping your equipment and workplace free of spray residue.

Cat. No.	Description
TT-771-2	Table-Tac, 2 oz. trial size
TT-771-1Q	Table-Tac, 1 qt. container
TT-771-1G	Table-Tac, 1 gal. container
TT-771-5G	Table-Tac, 5 gal. container
TT-771-55G	Table-Tac, 55 gal. container



Table-Tac Accessories

A.W.T. plastic spreader/scrapers are used to apply blackout to screens, adhesive to pallets, and any decals. Available in 4", 6" and 72" lengths.

Cat. No.	Description
PS-04	4" plastic spreader/scrapper – pkg. 12
PS-06	6" plastic spreader/scrapper – pkg. 12
PS-72	72" plastic spreader/scrapper

Different lengths available/special size cuts made to order.



Tac-Top™ One-Sided Paper Pallet Adhesive for Use with Table-Tac™ Water Soluble Adhesive - Fast, Easy Cleanup

A.W.T.'s smooth surface Tac-Top™ is easy to use. Cover top of pallet completely with Tac-Top, wrapping approximately 1" extra under the pallet. Then apply Table-Tac adhesive onto the paper to hold substrate in place, and you're ready to print. Tac-Top is easy to remove after using, leaving a clean pallet that has not been affected by inks or solvents. Simply pull off the Tac-Top and the clean pallet is ready for your next job. Because Tac-Top eliminates the time and cost to remove adhesive with solvents, solvent and rag disposal efforts are also minimized.

Cat. No.	Roll Size	Description
TT-181	18" x 100 yds. (46cm x 91m)	Description: Tac-Top, smooth paper, one-sided pallet adhesive
TT-182	24" x 100 yds. (61cm x 91m)	Description: Tac-Top, smooth paper, one-sided pallet adhesive
TT-181S		Trial Size Tac-Top™

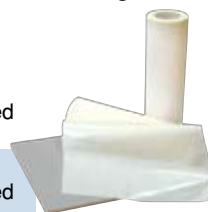

Stainless-steel Ink Spatulas with Rosewood Handles

Stainless-steel all-purpose spatulas have rosewood handles and brass rivets. Semi-flexible blades are ideal for stirring inks and mixing colors. Can also be used for removing excess ink from squeegees and screens and for general clean-up. Six per box.

Cat. No.	Description
SPAT-004	4" (10 cm) long spatula with 3/4" (1.9 cm) wide blade
SPAT-006	6" (15 cm) long spatula with 1" (2.5 cm) wide blade
SPAT-008	8" (20 cm) long spatula with 1-1/4" (3 cm) wide blade
SPAT-010	10" (25 cm) long spatula with 1-1/2" (3.8 cm) wide blade
SPAT-012	12" (30.4 cm) long spatula with 1-3/4" (4.4 cm) wide blade
SPAT-014	14" (35.5 cm) long spatula with 2" (5 cm) wide blade



A Division of The A.W.T. World Trade Group

4321 N. Knox Ave. • Chicago, IL 60641-1906 USA
 800.444.PART (within the USA) • 773.725.4900 • Fax: 773.777.0909
 parts@gpiparts.com • www.gpiparts.com

THE A.W.T. WORLD TRADE GROUP

Your Complete Manufacturing Source for Screen Printing Equipment, Supplies & Parts

Building on more than 30 years experience in serving clients in the graphic, textile and industrial markets, A.W.T. World Trade provides screen printers with a complete manufacturing source for prepress and printing supplies, machine parts, and remanufactured equipment.

Experience shows that when printers use a single manufacturing source, costly incompatibility problems between equipment lines and suppliers are greatly reduced. A.W.T. develops complete systems that work efficiently and economically to avoid printing errors, reduce downtime, and keep you profitable.

Our technical sales staff will make sure you choose the right system for your company's needs, delivering the performance you require at a cost within your budget. Industry experts in both technical support and service will confidently walk you through the setup and installation process for maximum productivity right from the start.

The A.W.T. World Trade Group was formed in 2002 when A.W.T. World Trade Inc. and Graphics Parts International Inc. purchased American Screen Printing Equipment.



**A.W.T.
World Trade Inc.**

www.awt-gpi.com



**American
M&M**

www.screenprintmachinery.com



**GRAPHIC PARTS
INTERNATIONAL INC.**

www.gpiparts.com

CORPORATE HEADQUARTERS AND MANUFACTURING FACILITY

A.W.T. World Trade Inc.

4321 N. Knox Avenue,
Chicago, IL 60641 USA

773.777.7100 • Fax: 773.777.0909

sales@awt-gpi.com

SALES AND DISTRIBUTION

Serving the Eastern U.S., Central and South America

A.W.T. World Trade Inc.

8984 N.W. 105th Way, Medley, FL 33178 USA

305.887.7500 • Fax: 305.887.2300

floffice@awt-gpi.com • www.awt-gpi.com

EUROPEAN SALES AND DISTRIBUTION

A.W.T. World Trade Europe BV

Xenonstraat 80, 1362 GH Almere, Holland

+(31)(0)(36)536.0873 • Fax: +(31)(0)(36)536.0626

info@awt-europe.com • www.awt-europe.com

For an A.W.T. dealer near you, contact:

